

W.S.46 for Amateur Use

By DAVID NOBLE (G3MAW*)
and DAVID M. PRATT (G3KEP)†

THE W.S. 46 walkie-talkie, available on the "surplus" market at a very reasonable price, has the advantage that it is suitable, without modification, for amateur use on the 40/80m bands on 'phone and m.c.w.

The transmitter and receiver are both crystal controlled with a common aerial coil which is tuned by the external "aerial trim." knob on the top panel of the unit. No r.f. stage is provided. Four plug-in coils are available, two of which are suitable for amateur use (3.6 to 4.3 Mc/s and 6.4 to 7.6 Mc/s). The unit can be tuned to three spot frequencies, any one of which may be selected by means of a single switch. Any three frequencies in the band required may be obtained by plugging in appropriate crystals and adjusting the internal preset trimmers provided. Two crystals are required for each channel. The frequency of the local oscillator is controlled by the receiver crystal and its anode coil is arranged so that any crystal within the given range will oscillate when plugged in; no retuning of the anode circuit is required.

The receiver i.f. is 1550 kc/s and crystals must be chosen such that there is a difference of 1550 kc/s between the receiver and transmitter crystals. On the 80m range the local oscillator crystal is 1550 kc/s above the signal frequency but on all other ranges it is on the i.f. below the signal frequency.

Circuit

The receiver consists of a crystal controlled frequency changer using a ARTP2 triode-pentode with a Pierce oscillator circuit, the input grid being connected to the transmitter anode circuit. Two i.f. amplifier stages are provided using ARP12 valves (V2, V3). The second stage is used in a reflex circuit as the a.f. output valve,

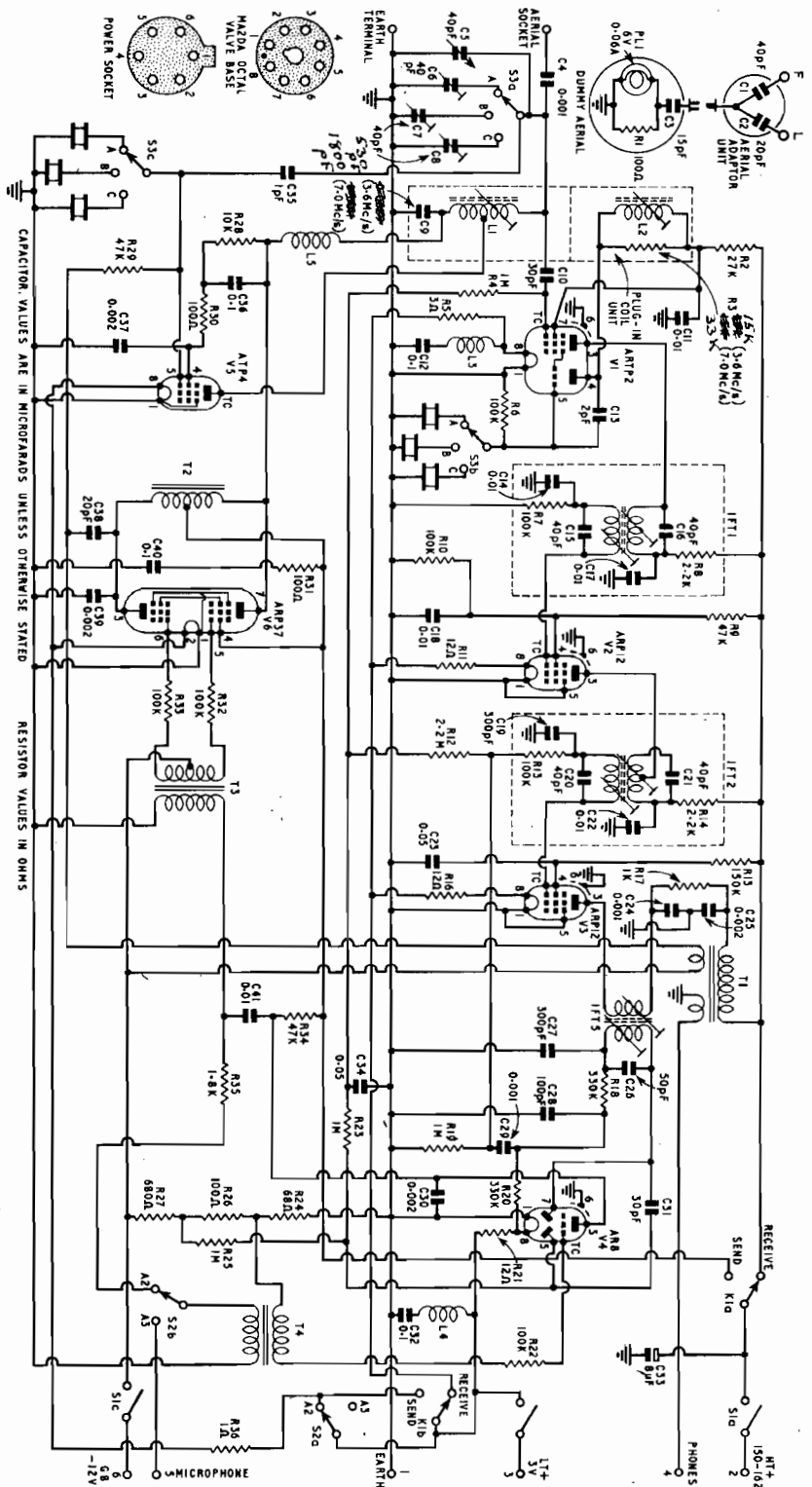
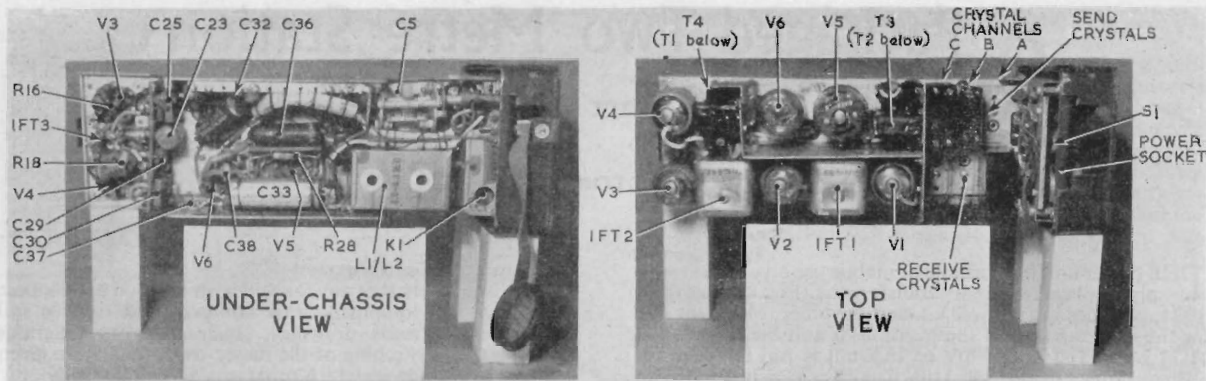

Fig. 1. Circuit diagram of the W.S.46.

* "Heather Bank," Hillings Lane, Menston, Ilkley, Yorks.

† "Glenluc," Lyndale Road, Eldwick, Bingley, Yorks.



The locations of the principal components are shown in these two views of the unit.

detection being provided by a diode of the AR8 (V4). The other diode is used for a.v.c. while the triode section is used as the m.c.w. oscillator and as the driver to the ARP37 push-pull modulator valve. The transmitter itself employs a ATP4 in a modulated crystal oscillator circuit.

Change-over Switching

When the unit is operated on m.c.w., the transmitter heaters are switched on, both on send and on receive, and the send/receive button is used as the Morse key. On telephony, however, the send/receive button switches the heater supply to the valves in use. Due to the extra heater supply when receiving m.c.w., current drain is greater and for long receiving periods while using m.c.w. it is advisable to return the emission switch to the "R.T." position.

Modulation

Anode and screen modulation of the p.a. is used, the microphone being a magnetic throat type. Originally, the unit used "Microphone and receiver head-gear assembly No. 5," but different types of microphone may be tried in order to obtain better speech quality.

Aerial

The unit is primarily designed for use with a 8 ft. vertical whip aerial which is plugged directly into the set. An aerial adapter is provided, however, so that other types of aerials may be used. A 16 ft. vertical wire may be connected to terminal "F" of the adapter unit, or a quarter wave wire may be used if connected to terminal "L" of the unit.

So that it can be ascertained that the unit is working correctly before actual radiation is attempted, a dummy aerial with indicator bulb is fitted to the top panel of the set.

Battery Supplies

A type 18 Set battery is suitable for use with this equipment, which requires an I.T. supply of 3 volts with -12 volts grid bias and 162 volts for h.t. If the battery carrier and attached junction box is available, then the type 18 Set battery can be plugged in directly. For readers who wish to use this equipment but who do not possess the junction box, circuit information is given in Fig. 1 to enable a suitable junction box to be constructed.